

R-305

3-Way Low Pressure Pilot Valve



Features:

- Pilot actuates valve with low pressure signal
- Multiple porting speeds piping
- Micro gap construction - snap action and no blow by
- Balanced design allows speed control at exhausts

Performance:

Flow (SCFM @ 100 psig).....	9
Pilot pressure (psig) minimum.....	15
Temperature.....	32° to 180° F
Working pressure.....	0 to 150

Description:

R-305 is a 3-way, spring-return, fully ported valve with a low pressure pilot. Pilot pressure signals as low as 10 psig will actuate the valve. The valve can be used normally-OPEN, normally-CLOSED, as a selector or as a diverter. The R-305 may be used in place of an R-301 valve where a lower pilot actuation pressure is desired. It can also be used as a 2-way valve by plugging the exhaust ports.

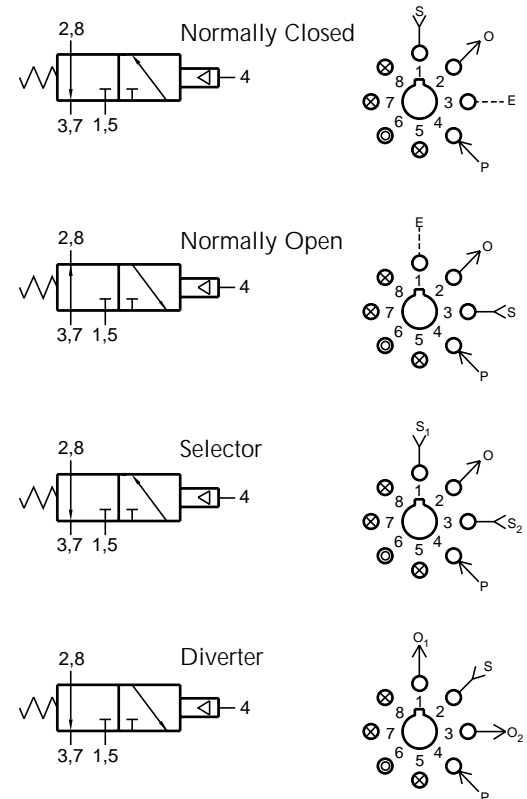

R-310

3-Way Reset Valve



Features:

- Indicator shows valve in shaded position
- Multiple porting speeds piping
- Micro gap construction - snap action and no blow by
- Balanced design allows speed control at exhausts
- Unique piloted spring reset

Performance:

Flow (SCFM @ 100 psig).....	9
Pilot pressure (psig) minimum (against spring).....	40
Pilot pressure (psig) minimum (spring retracted).....	20
Temperature.....	32° to 180° F
Working pressure.....	0 to 150

Description:

R-310 is a 3-way, fully ported valve with a special air retracted spring return that will return the valve to a definite position when there is no signal at ports 5 and 4. This "reset" feature may be used in circuits in the event of loss of air pressure or to change the operating characteristics of the valve in the circuit in response to an independent input at port 5. When port 5 is not piloted, the R-310 acts as an R-301 3-way spring return, fully ported valve. When port 5 is actuated, the R-310 acts as an R-302 3-way, two position valve. With no signal at port 5, a signal at port 6 acts as an auxiliary pilot type valve and will override a signal at port 4.

